

DOC. NO.:	FT.TP.111
DATE:	11-14-15
REVISION:	IR
PAGE:	1 OF 7

PART 1 FLAMMABILITY TEST REPORT

Quality Control Testing Fiber Protector America, LLC

**FT.TP.111
REV: IR
Date: 11-14-15**

**Supports comparison testing of leather with and
without application of Fiber Protector**

Doc. No.:	FT.TP.111
DATE:	11-14-15
REVISION:	IR
PAGE:	2 OF 7

Revisions

Rev	Prepared By	Document Approval Signature	Date	Revision Summary
IR	Brad Shelton		11-14-15	Initial Release

Table of Contents

1. Purpose	2
2. Reference Documents	3
3. Discussion of Testing	3
4. Test Requirements	3
5. Test procedures and Equipment	4
6. Test List	4
7. Test Results	7

1.0 Purpose

This testing is in supports comparison testing of CL-1048 Castle Rock leather with and without application of Firber Protector. Leather test specimens were supplied by the company listed below.

Fiber Protector America, LLC
1100 Jones Street
Little Rock, AR 72202
501-374-4402

This plan includes following:

- Complete identification of materials.
- Test method to be used.
- A numerical test list of items to be tested.

Upon completion of testing Test Set-Up Checklist and Test Results will be added to section 8.

DOC. No.:	FT.TP.111
DATE:	11-14-15
REVISION:	IR
PAGE:	3 OF 7

2.0 Reference Documents

General Documents

FT.WI.01, Rev. NC (dated 06-13-13)	Flammability Test Procedures for FAA Certification
------------------------------------	--

Part 23 Regulations

14 CFR 25.853 AMDT(25-116)	Compartment Interiors
Appendix F (Sec. F25.1) AMDT (25-111)	Test Criteria and Procedures

3.0 Discussion of Testing

A coupon test list is presented in section 6.0. Upon completion of testing Flammability Result Sheets will be included in section 7.0.

Note: Two Sets of 3 specimens were tested for both configurations (With Fiber Protector and Without). Testing on this leather does not appear to show any negative flammability effects when Fiber Protector is applied.

4.0 Test Requirements

For Comparison Testing the Leather/Fiber Protector combinations will be tested to the 12 second vertical test.

Compliance Requirements

14 CFR Part 25.853, AMDT Level 25-116

(a) Materials (including finishes or decorative surfaces applied to the materials) must meet the applicable test criteria prescribed in part I of appendix F of this part, or other approved equivalent methods, regardless of the passenger capacity of the airplane.

Testing Requirements

Part I (a)(1)(ii) Floor covering, textiles (including draperies and upholstery), seat cushions, padding, decorative and nondecorative coated fabrics, leather, trays and galley furnishings, electrical conduit, air ducting, joint and edge covering, liners of Class B and E cargo or baggage compartments, floor panels of Class B, C, D, or E cargo or baggage compartments, cargo covers and transparencies, molded and thermoformed parts, air ducting joints, and trim strips (decorative and chafing), that are constructed of materials not covered in subparagraph (iv) below, must be self-extinguishing when tested vertically in accordance with the applicable portions of Part I of this Appendix or other approved equivalent means. The average burn length may not exceed 8 inches, and the average flame time after removal of the flame source may not exceed 15 seconds. Drippings from the test specimen may not continue to flame for more than an average of 5 seconds after falling.

DOC. NO.:	FT.TP.111
DATE:	11-14-15
REVISION:	IR
PAGE:	4 OF 7

5.0 Test Procedures and Equipment

Testing will take place at FLAME-TEK LLC. Laboratory contact information listed below.

FLAME-TEK
1515 North Center, Suite 1
Lonoke, AR 72086

Testing will follow procedures outlined in FT.WI.01 (Flammability Test Procedures for FAA Certification). Prior to testing, the lab will be set-up per FT.FR.03 (Test Set-Up Checklist).

6.0 Test List

The test list below provides a numerical list of the item(s) to be tested. Vertical test samples measure 3" X 12". Flame is to be applied per FT.WI.01.

DOC. No.:	FT.TP.111
DATE:	11-14-15
REVISION:	IR
PAGE:	5 OF 7

Test Plan Item Number	Specimens 1 and 2 (Treated)
Component Location	Quality Control Testing
Test Method	CFR 25.853, 12 sec Vertical Test

TEST SPECIMEN ISOMETRIC SKETCH

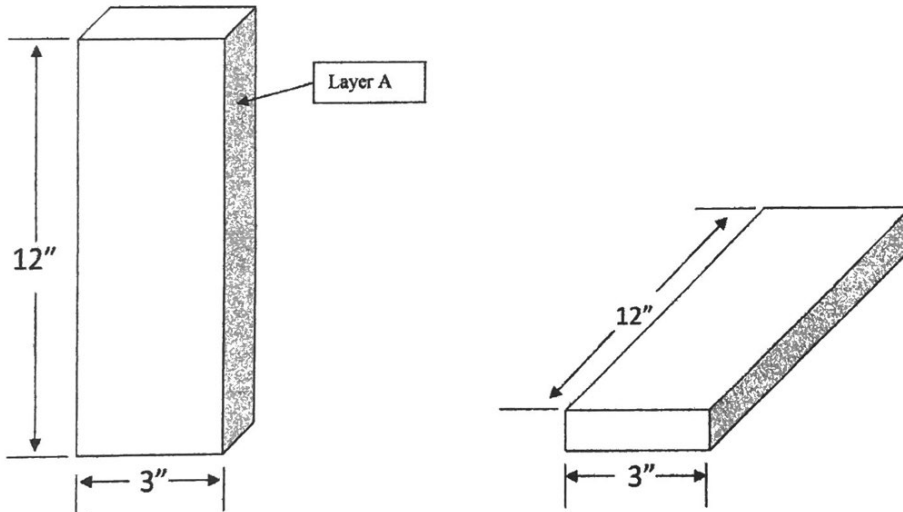

Layer Identification Table

Layer	Material PN	Manufacturer	Lot/Batch	Comments
A	CL-1048 CASTLEROCK	N/A	N/A	Leather

Fiber Protector is applied to Specimens 1 and 2.

Doc. No.:	FT.TP.111
DATE:	11-14-15
REVISION:	IR
PAGE:	6 OF 7

Test Plan Item Number	Specimens 3 and 4 (Not Treated)
Component Location	Quality Control Testing
Test Method	CFR 25.853, 12 sec Vertical Test

TEST SPECIMEN ISOMETRIC SKETCH

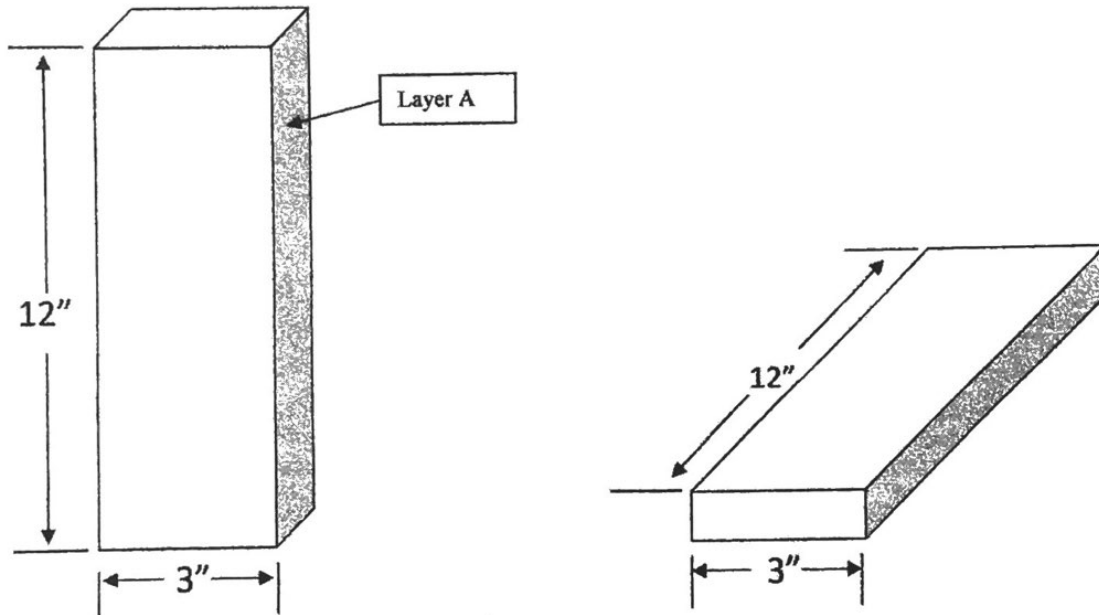

Layer Identification Table

Layer	Material PN	Manufacturer	Lot/Batch	Comments
A	CL-1048 CASTLEROCK	N/A	N/A	Leather

No Fiber Protector is applied to Specimens 3 and 4.

DOC. NO.:	FT.TP.111
DATE:	11-14-15
REVISION:	IR
PAGE:	7 OF 7

7.0 Test Results

**Attachments: Flammability Test Set-Up Checklist
Flammability Test Results**

FLAMMABILITY TEST SET-UP CHECKLIST

FLAME-TEK, LLC

FT.FR.03

Flammability Test Set-Up Checklist

Aircraft Model and Serial Number: Fiber Protector Quality Control Testing

Technician: Brad Shelton 

Date: 11/14/15

Note: This document includes three test set-up sections. Section 1 items must be checked prior to each test. During the daily period of testing, if at any time the burner is shut off to stop testing, the items in section 2 must be checked again prior to start up. Section 3 items must be checked at least daily.

Section 1

1.1 Flame Height

- a. For Vertical, Horizontal and 45-Degree testing flame extends at least 1.5 inches above the top of the burner barrel.
- b. If using methane it is desirable to have two prongs for measuring the flame height with one prong to measure inner cone height and the other prong to measure tip of the flame. For methane it has been determined when the inner cone is at least 7/8 inch and the tip of flame is at least 1.5 inch, the proper flame profile is achieved. Flame height should not exceed 1.6 inches. A 1.5 inch flame height is considered nominal and should be the desired height for test setup.
- c. For 60-Degree wire testing outer cone of the flame must be at least 3 inches in length. Inner cone should be approximately 1 inch in length. Flame Height should not exceed 3.1 inches.

1.2 Test Specimen

- a. Specimen Selection,
- b. Warp and Fill (when applicable),
- c. At least 3 specimens for each separate set of specimens,
- d. Vertical burn: Specimen Sizes of at least 3" x 12" inches unless actual size is smaller,
- e. 45-Degree burn: Specimen size of 10" x 10". Must have exposed area of at least 8" x 8".
- f. Specimen thickness will be the same as that used in the airplane with the following exceptions:
 - i. If multiple thickness, the minimum will be tested.
 - ii. Foam parts thicker than 1/2 inch will be tested in 1/2 inch thickness.
 - iii. Parts that are smaller than the size of a specimen and cannot have specimens cut from them may be tested using a flat sheet of the material used to fabricate the part in the actual thickness used on the aircraft.
- g. 60-Degree wire test: Specimen size of at least 30 inches. Specimen span between lower clamp and upper pulley or rod will be at least 24 inches.

Document	REV	Date
FT.FR.03	NC	06-13-13

3.4 Burner Fuel

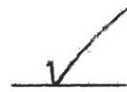

- a. Methane gas (99% minimum purity) or other acceptable to FAA,

3.5 Timer

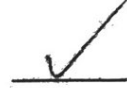

- a. Stopwatch or other device calibrated to the nearest 0.1 second to measure flame application, flame time, and drip flame time,

3.6 Ruler

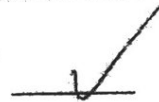

- a. A ruler or scale graduated to the nearest 0.1 inch required to measure burn length,

Document	REV	Date
FT.FR.03	NC	06-13-13

FLAMMABILITY TEST RESULTS

FLAMMABILITY MATERIAL TEST CERTIFICATE

Bunsen Burner Test Data Sheet Test Lab: FLAME-TEK Authorization: N/A

PART NUMBER: CL-1048 CASTLEROCK	Lot#: N/A	Aircraft Model: N/A	PO#: N/A	Test Specimen # 1 (Treated)
MANUFACTURER: N/A	THICKNESS: .10"	Material: Leather	DIRECTION: N/A	

MATERIAL DESCRIPTION: Fiber Protector applied to CL-1048 CASTLEROCK Leather. Conditioning Hrs. 24

TEST METHOD FAR 25.853 Pass/Fail Criteria (Max Average)

Appendix F	IGNITION TIME - MATERIAL TEST POSITION	FEDERAL AVIATION REGULATION	EXTINGUISH TIME	BURN LENGTH	DRIP EXTINGUISH	BURN RATE AVG.	FLAME PENETRATION	AFTER GLOW
Part 1 (a)(1)(i)	1. 60 SECOND IGNITION - VERTICAL	FAR 25.853(e)	15 SEC (AVG)	6 IN. (AVG)	3 SEC (AVG)			
Part 1 (a)(1)(ii)	2. 12 SECOND IGNITION - VERTICAL	FAR 25.853(e)	15 SEC (AVG)	8 IN. (AVG)	5 SEC (AVG)			
Part 1 (a)(1)(iv)	3. 15 SECOND IGNITION - HORIZONTAL	FAR 25.853(e)				2.5 IN. MIN		
Part 1 (a)(1)(v)	4. 15 SECOND IGNITION - HORIZONTAL	FAR 25.853(e)				4 IN. MIN		
Part 1 (a)(2)(ii)	5. 30 SECOND IGNITION - 45 DEGREE	FAR 25.853(e)	15 SEC (AVG)				NONE	10 SEC (AVG)
Part 1 (a)(3)	6. 30 SECOND IGNITION - 60 DEGREE	FAR 25.853(e)	30 SEC (AVG)	3 IN. (AVG)	3 SEC (AVG)			

TEST RESULTS

SAMPLE NO.	TEST METHOD	EXTINGUISH TIME (SECS)	BURN LENGTH (INCHES)	DRIP EXTINGUISH TIME (SEC)	BURN TIME (SEC)	BURN RATE (IN/MIN)	AFTER GLOW (SECS)	Comment:
1	Part 1 (a)(1)(ii)	0	.3	0	12			Testing Conducted for Fiber Protector America, LLC 1100 Jones Street Little Rock, AR 72202 501-374-4402
2	Part 1 (a)(1)(ii)	0	.3	0	12			
3	Part 1 (a)(1)(ii)	0	.3	0	12			
Average		0	.30	0				

Test Date: 11-14-15 Witnessed by: Brad Shelton FAA DER

Test Time: 6:20 P.M. PASS FAIL

Flame Temp: 1565 °F

Document	REV	DATE
FT.FR.01	NC	06-13-13

FLAMMABILITY MATERIAL TEST CERTIFICATE

Bunsen Burner Test Data Sheet

Test Lab: **FLAME-TEK**

Authorization: **N/A**

PART NUMBER: CL-1048 CASTLEROCK	Lot#: N/A	Aircraft Model: N/A	PO#: N/A	Test Specimen # 2 (Treated)
MANUFACTURER: N/A	THICKNESS: .10"	Material: Leather	DIRECTION: N/A	

MATERIAL DESCRIPTION: Fiber Protector applied to CL-1048 CASTLEROCK Leather.

TEST METHOD FAR 25.853

Pass/Fail Criteria (Max Average)

Appendix F	IGNITION TIME - MATERIAL TEST POSITION	FEDERAL AVIATION REGULATION	EXTINGUISH TIME	BURN LENGTH	DRIP EXTRUCTION	BURN RATE AVG.	FLAME PENETRATION	AFTER GLOW
Part 1 (a)(1)(i)	1. 60 SECOND IGNITION - VERTICAL	FAR 25.853(a)	15 SEC (AVG)	6 IN. (AVG)	3 SEC (AVG)			
Part 1 (a)(1)(ii)	2. 12 SECOND IGNITION - VERTICAL	FAR 25.853(a)	15 SEC (AVG)	8 IN. (AVG)	5 SEC (AVG)			
Part 1 (a)(1)(iii)	3. 15 SECOND IGNITION - HORIZONTAL	FAR 25.853(a)				2.5 IN. MIN		
Part 1 (a)(1)(iv)	4. 15 SECOND IGNITION - HORIZONTAL	FAR 25.853(a)				4 IN. MIN		
Part 1 (a)(2)(i)	5. 30 SECOND IGNITION - 45 DEGREE	FAR 25.853(a)	15 SEC (AVG)				NONE	10 SEC (AVG)
Part 1 (a)(3)	6. 30 SECOND IGNITION - 60 DEGREE	FAR 25.853(a)	30 SEC (AVG)	3 IN. (AVG)	3 SEC (AVG)			

TEST RESULTS

SAMPLE NO.	TEST METHOD	EXTINGUISH TIME (SECS)	BURN LENGTH (INCHES)	DRIP EXTRUCTION TIME (SEC)	BURN TIME (SEC)	BURN RATE (IN/MIN)	AFTER GLOW (SECS)	Comment:
1	Part 1 (a)(1)(ii)	0	.3	0	12			Testing Conducted for Fiber Protector America, LLC 1100 Jones Street Little Rock, AR 72202 501-374-4402
2	Part 1 (a)(1)(iii)	0	.4	0	12			
3	Part 1 (a)(1)(iv)	0	.3	0	12			
Average		0	.33	0				

Test Date: 11-14-15

Witnessed by: Brad Shelton FAA DER

Flame Temp: 1565 °F

Test Time: 6:25 P.M.

PASS

FAIL

Document	REV	DATE
FT.FR.01	NC	06-13-13

FLAMMABILITY MATERIAL TEST CERTIFICATE

Bunsen Burner Test Data Sheet

Test Lab: **FLAME-TEK**

Authorization: **N/A**

PART NUMBER: CL-1048 CASTLEROCK	Lot#:	Aircraft Model:	PO#:	Test Specimen #
	N/A	N/A	N/A	3 (Not Treated)
MANUFACTURER: N/A	THICKNESS:	Material:	DIRECTION:	
	.10"	Leather	N/A	

MATERIAL DESCRIPTION: CL-1048 CASTLEROCK Leather, Fiber Protector NOT applied.

Conditioning Hrs. 24

TEST METHOD FAR 25.853

Pass/Fail Criteria (Max Average)

Appendix F	IGNITION TIME - MATERIAL TEST POSITION	FEDERAL AVIATION REGULATION	EXTINGUISH TIME	BURN LENGTH	DRIP EXTINGUISH	BURN RATE AVG.	FLAME PENETRATION	AFTER GLOW
Part 1 (a)(1)(i)	1. 60 SECOND IGNITION - VERTICAL	FAR 25.853(a)	15 SEC (AVG)	6 IN. (AVG)	3 SEC (AVG)			
Part 1 (a)(1)(ii)	2. 12 SECOND IGNITION - VERTICAL	FAR 25.853(a)	15 SEC (AVG)	8 IN. (AVG)	5 SEC (AVG)			
Part 1 (a)(1)(iv)	3. 15 SECOND IGNITION - HORIZONTAL	FAR 25.853(a)				2.5 IN. MIN		
Part 1 (a)(1)(v)	4. 15 SECOND IGNITION - HORIZONTAL	FAR 25.853(a)				4 IN. MIN		
Part 1 (a)(2)(ii)	5. 30 SECOND IGNITION - 45 DEGREE	FAR 25.853(a)	15 SEC (AVG)				NONE	10 SEC (AVG)
Part 1 (a)(3)	6. 30 SECOND IGNITION - 60 DEGREE	FAR 25.853(a)	30 SEC (AVG)	3 IN. (AVG)	3 SEC (AVG)			

TEST RESULTS

SAMPLE NO.	TEST METHOD	EXTINGUISH TIME (SECS)	BURN LENGTH (INCHES)	DRIP EXTINGUISH TIME (SEC)	BURN TIME (SEC)	BURN RATE (IN/MIN)	AFTER GLOW (SECS)	Comment:
1	Part 1 (a)(1)(i)	0	.4	0	12			Testing Conducted for Fiber Protector America, LLC 1100 Jones Street Little Rock, AR 72202 501-374-4402
2	Part 1 (a)(1)(ii)	0	.3	0	12			
3	Part 1 (a)(1)(iv)	0	.3	0	12			
Average		0	.33	0				

Test Date: 11-14-15

Witnessed by: Brad Shelton FAA DER

Flame Temp: 1565 °F

Test Time: 6:30 P.M.

PASS

FAIL

Document	REV	DATE
FT.FR.01	NC	06-13-13

FLAMMABILITY MATERIAL TEST CERTIFICATE

Bunsen Burner Test Data Sheet Test Lab: FLAME-TEK Authorization: N/A

PART NUMBER: CL-1048 CASTLEROCK	Lot#: N/A	Aircraft Model: N/A	POF: N/A	Test Specimen # 4 (Not Treated)
MANUFACTURER: N/A	THICKNESS: .10"	Material: Leather	DIRECTION: N/A	

MATERIAL DESCRIPTION: CL-1048 CASTLEROCK Leather, Fiber Protector NOT applied. Conditioning Hrs. 24

TEST METHOD FAR 25.853		Pass/Fail Criteria (Max Average)							
Appendix F	IGNITION TIME - MATERIAL TEST POSITION	FEDERAL AVIATION REGULATION	EXTINGUISH TIME	BURN LENGTH	DRIP EXTINGUISH	BURN RATE AVG.	FLAME PENETRATION	AFTER GLOW	
Part 1 (a)(1)(i)	1. 60 SECOND IGNITION - VERTICAL	FAR 25.853(e)	15 SEC (AVG)	6 IN. (AVG)	3 SEC (AVG)				
Part 1 (a)(1)(ii)	2. 12 SECOND IGNITION - VERTICAL	FAR 25.853(e)	15 SEC (AVG)	8 IN. (AVG)	5 SEC (AVG)				
Part 1 (a)(1)(iv)	3. 15 SECOND IGNITION - HORIZONTAL	FAR 25.853(e)				2.5 IN. MIN			
Part 1 (a)(1)(iv)	4. 15 SECOND IGNITION - HORIZONTAL	FAR 25.853(e)				4 IN. MIN			
Part 1 (a)(2)(ii)	5. 30 SECOND IGNITION - 45 DEGREE	FAR 25.853(e)	15 SEC (AVG)				NONE	10 SEC (AVG)	
Part 1 (a)(3)	6. 30 SECOND IGNITION - 60 DEGREE	FAR 25.853(e)	30 SEC (AVG)	3 IN. (AVG)	3 SEC (AVG)				

TEST RESULTS

SAMPLE NO.	TEST METHOD	EXTINGUISH TIME (SECS)	BURN LENGTH (INCHES)	DRIP EXTINGUISH TIME (SEC)	BURN TIME (SEC)	BURN RATE (IN/MIN)	AFTER GLOW (SECS)	Comment:
1	Part 1 (a)(1)(ii)	0	.3	0	12			Testing Conducted for Fiber Protector America, LLC 1100 Jones Street Little Rock, AR 72202 501-374-4402
2	Part 1 (a)(1)(ii)	0	.4	0	12			
3	Part 1 (a)(1)(ii)	0	.3	0	12			
Average		0	.33	0				

Test Date: 11-14-15 Witnessed by: Brad Shelton FAA DER

Test Time: 6:34 P.M. PASS FAIL

Flame Temp: 1565 °F

Document	REV	DATE
FT.FR.01	NC	06-13-13